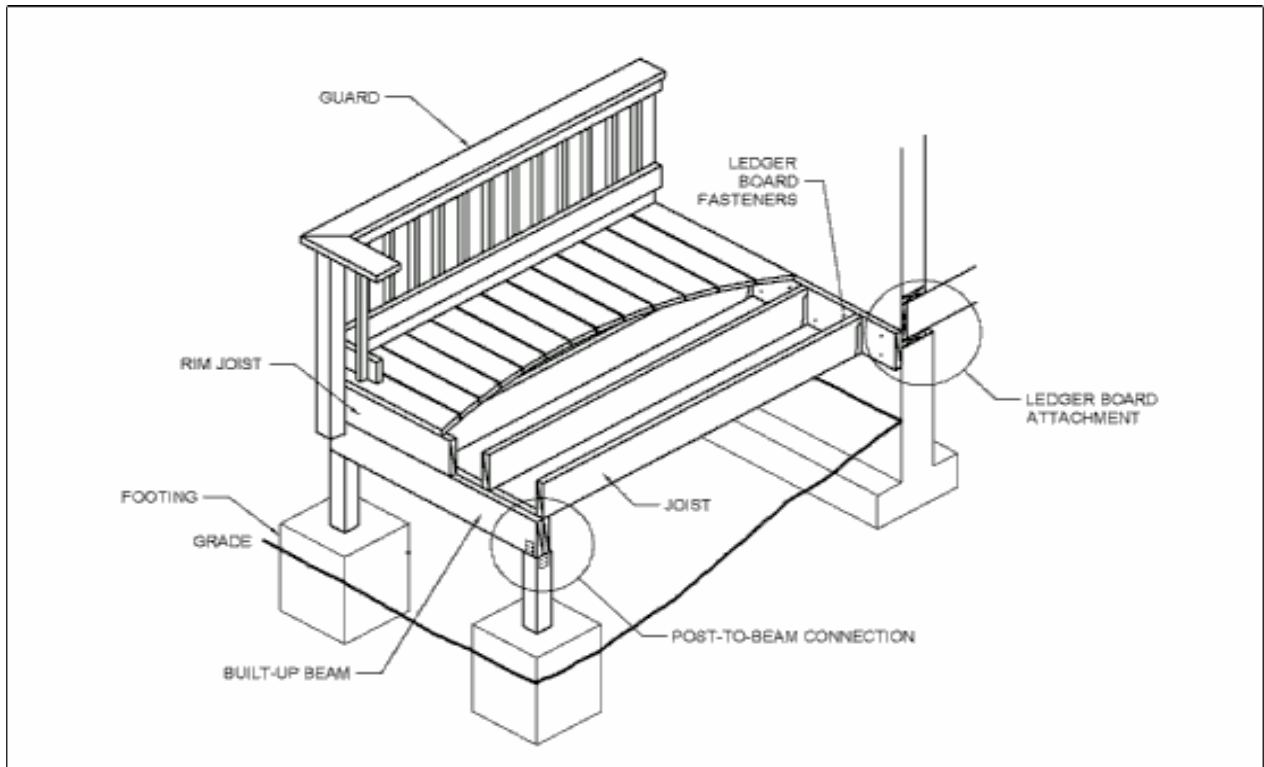




City of Corvallis - Development Services Division  
 501 SW Madison Avenue, P.O. Box 1083, Corvallis, OR 97339-1083  
 Phone 541-766-6929 Fax 541-766-6936  
 E-Mail: [development.services@ci.corvallis.or.us](mailto:development.services@ci.corvallis.or.us)

# Typical Deck Details

YOU CAN USE TO BUILD YOUR DECK  
 Compliant with 2005 ORSC  
 Revised February 14, 2008



Introduction .....	2	Lateral Support of Decks .....	10
Obtaining Permits.....	2	Joist Hangers.....	11
General Notes .....	2	Rim Joist Requirements.....	12
Getting Started .....	3	Built-up Beam Requirements.....	12
Beam, Joist, and Footing Sizes .....	4	Post-to-Beam Requirements .....	12
Post Sizes .....	6	Footings .....	13
Ledger Attachment Requirements .....	6	Guardrail Requirements.....	13
Prohibited Ledger Attachments.....	8	Stair Requirements .....	15
Ledger Board Fasteners .....	9	Stair Handrail Requirements .....	17
Freestanding Decks .....	10	Framing at Chimney or Bay Window .....	17

**This handout includes details for a typical deck as it applies to single span, one level, single-family residential decks only. Decks must be constructed in strict conformance with the details contained herein. If a permit is required, a copy of approved plans must be on the job site and available to the inspector during the inspection process. This guide is intended to help provide typical information needed for constructing a deck.**

## INTRODUCTION

These plans and details are provided to assist you in your deck construction, for obtaining a building permit (when required), or simply to aide you in constructing a deck that does not require a permit. **Before proceeding, always check with the City for land use, zoning, or other regulations that may affect your project.**

### When Do I Need A Permit For A Deck?

A building permit is required for all decks that are 30 inches or more above grade. A building permit is not required for decks that are less than 30 inches above the ground AND not less than 3 feet from a property line.

### How Do I Get A Permit?

If you need a building permit for your deck, you will need to submit plans of sufficient detail to your local building department to indicate what you want to build. Two complete sets of plans will be required. One approved set will be returned to you to keep on sited for inspections. The other set will be kept on file by the building department.

Plans will be required to contain a Site Plan, a Floor Plan, and Construction Details. The Site Plan must be drawn to scale and show an outline of your property (property lines), the house, and outline of where you will be locating the deck with dimensions from it to the property line. Be sure to indicate any additional existing accessory buildings or structures (shed, pool, retaining wall, etc.). The Site Plan must also have a north arrow and location of any easements. Two foot contour lines must be shown to show slopes that could effect your deck structure.

The Floor Plan must be drawn to scale and show the deck shape, construction materials proposed to be used, and footings. It must have sufficient dimensions to determine spans, beam and footing locations, and deck size. Plans must indicate how big the footings, beams, joists, posts, and ledgers are proposed to be as well as all connections as described in this handout.

The Construction Details are required for ledger attachments, stair details, handrail and guardrail details, etc. as they apply. The following handout will help you determine what ones apply to your deck.

### How Big Do The Footings, Beams, And Joists Need To Be?

The detail in the attached examples will help you determine how big the footings, beams, joists, posts, and ledgers need to be. Much of it depends on the size of the deck, what size beams and joists you want to use, and how far apart you want to place the beams, posts, and footings.

### General Notes

1. All lumber shall be grade #2 Douglas-Fir, Hem-Fir, or better and shall be pressure treated (to resist insect and dry rot) in accordance with American Wood-Preservers' Association Standards (Category). Decking material of redwood or cedar does not require pressure treatment as it has a natural resistance to decay. The pressure-treatment category identified below will be identified on the lumber. The level of treatment depends on the use as follows:
  - a. Decking material, railings, joists, posts, and beams must be treated to a Category UC3B.
  - b. Posts and other woods located on, in, or in contact with the ground must be a Category UC4B.
  - c. Any wood less than six inches above the ground or in contact with concrete must be a Category UC4A.
2. The level of preservative treatment is noted on the tags fixed to the ends of the wood members. **Remember, any time you make a cut, treat the cut end of the wood with a paint-on preservative. Cut ends expose the inner untreated wood to potential moisture and insect damage.**
3. All nails shall be "common" or "box" galvanized. It is recommended that "common" nails be used. They have a thicker shank and are stronger than "box" nails.
4. **New pressure treatment methods use chemicals that will prematurely corrode standard fasteners, hardware, and flashing when in contact with pressure treated lumber; and as a result, fastener and hardware requirements have changed. Note the following:**
  - a. **All screws and nails shall be hot-dipped galvanized or stainless steel.**
  - b. **All hardware (joist hangers, cast-in-place post anchors, etc.) shall be galvanized with 1.85 oz/sf of zinc (G-185 coating) or shall be stainless steel. Look for products such as "Zmax" from Simpson Strong-Tie or "Triple Zinc" from USP.**

5. Decks constructed according to this handout are not designed to support spas or hot tubs. Installation of spas or hot tubs will require additional structural supports. It may be necessary to employ the services of a licensed engineer to properly design the required support.
6. Decks shall not be attached to house overhangs, bay windows, brick veneers, or chimneys.
7. Deck designs that deviate from the conditions of this handout may require engineering.
8. Inspections:
  - a. A footing inspection and a final inspection are required on all decks.
  - b. Footing inspections are required PRIOR to the placement of concrete.
  - c. Framing and final inspections may be combined if all portions of the deck framing and mechanical attachments are at least four feet above grade.
  - d. It is the responsibility of the permit holder or the permit holder's representative to notify the City when stages of construction are reached that requires an inspection. The City inspection request line is 541-766-6745.
9. All decking material shall be composed of 2x4, 2x6, or five quarter ("5/4") boards. Attach decking to each joist with two 10d nails or two #8 screws. Decking may be placed from an angle perpendicular to the joists to an angle of 45 degrees to the joists. Decking must have a span length such that each board bears on a minimum of two joists.
10. Plastic or composite decking products may be used as a substitute for conventional wood decking, but installation and span lengths of the substituted material must be in strict conformance with the product listing and the manufacturer's installation instructions. Copies of the manufacturer's installation instructions must be submitted with this handout and permit application.
11. Footings for decks constructed according to this handout shall not be placed on ground with a slope greater than 2 horizontal for every 1 vertical.

## Getting Started

To effectively use the information contained in this document, you will need to do the following:

1. Determine if your deck requires a permit. Note: even if a permit is not required, zoning regulations (setbacks) and public utility easement restrictions are still applicable. **Before proceeding, always check with the City for land use, zoning, or other regulations that may affect your project.**
2. Determine where your property lines are located and what setbacks the City requires from the property line to the edge of the deck.
3. Determine if you have any public easements on your property and whether or not the deck can be constructed over the easement, if applicable (in most cases, you cannot build over a public easement).
4. Determine how big and what configuration you want your deck. Note: The drawings contained in this document may indicate square or rectangular configurations; however, configurations can be diamond, trapezoidal, or other shapes as long as the longest spans are used to determine beam, joist, and footing sizes. The deck can have up to a two-foot maximum joist and/or beam overhang. See Figures 1, 2, and 3. (Beams are identified as item "A", posts as item "B", joists as item "C," and footings as item "D.") **It is recommended that you first determine the joist span "C," and then note what beam and footing sizes you will need.**

## BEAM, JOIST, AND FOOTING SIZES

The span of a joist is measured from the centerline of bearing at one end of the joist to the centerline of bearing at the other and does not include overhangs. Maximum joist span lengths are noted in Table A. See Figures 1 and 2 for joist span types.

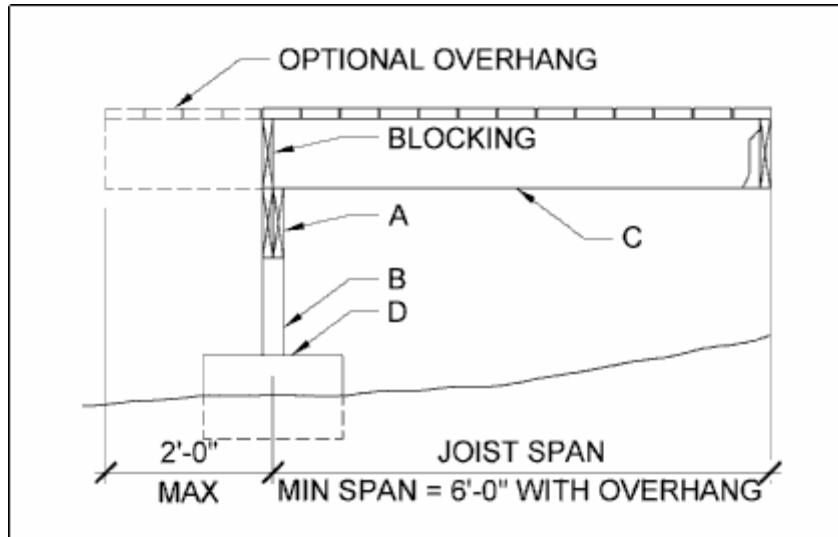


Figure 1 - Joist Span – Deck Attached At House

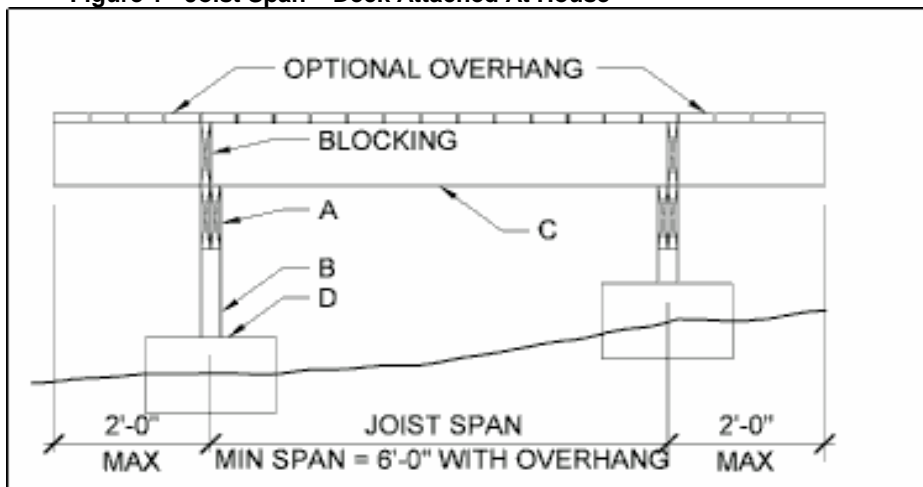
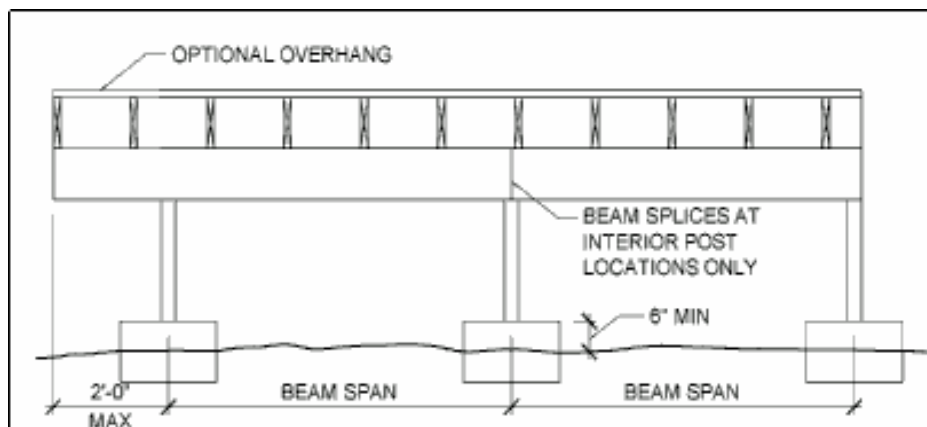


Figure 2 - Joist Span - Free-Standing Deck



5. Table A provides you with the information to determine how big the footings, beams, and joists need to be. The size will depend on how big the deck will be and how many footings and posts are going to be.

be used; how far the beam(s) will span from post-to-post (or ledger); and how far the joist will span from beam-to-beam. To start with, contact your city plans examiner to determine what the assumed soil bearing value is for your area. This document has footing details for soils that can support 1,500 pounds per square foot (psf) (See Table A). If you have soil bearing of less than 1000 psf, you will need to consult with your local jurisdiction. Note: The footing details are based on native soil and not soil that has been deposited on your property (fill) in depths greater than 12 inches. The footing details require a footing that is a minimum of 8 inches in height and the bottom located a minimum of 12 inches below the finished grade. If you have fill material that is greater than 12 inches, your footing will need to extend through the fill to native soil. Footings for freestanding decks (those not attached to the house) are not required to be placed below the frost line.

**TABLE A**  
**DECKS ON SOIL WITH A 1500 PSF BEARING CAPACITY**  
 (Note: All footings are to be placed a minimum of 12 inches below the surface of the finished grade and cannot be placed on fill.)

1.) If you have a beam "A" that is:	And 2.) you have posts "B" supporting the beam spaced:	Then 3.) you can only span the joists "C":	And 4.) the minimum size joist you can use is:	And 5.) they can be spaced a maximum of:	And 6.) the footings "D" supporting the posts will need to be a minimum of:
4x6 or (2) 2x6	6'-0" apart	<b>6'-0"</b>	2x6	24" apart	14"x14"x 8" or 16" diameter x 8"
4x8 or (2) 2x8	8'-6" apart	<b>6'-0"</b>	2x6	24" apart	18"x18"x 8" or 20" diameter x 8"
4x10 or (2) 2x12	10'-6" apart	<b>6'-0"</b>	2x6	24" apart	20"x20"x10" or 23" diameter x 10"
4x12	12'-6" apart	<b>6'-0"</b>	2x6	24" apart	22"x22"x10" or 25" diameter x 10"
4x6 or (2) 2x8	6'-0" apart	<b>8'-0"</b>	2x6 or 2x8	16" apart or 24" apart	18"x18"x 8" or 20" diameter x 8"
4x8 or (2) 2x10	8'-0" apart	<b>8'-0"</b>	2x6 or 2x8	16" apart or 24" apart	20"x20"x10" or 23" diameter x 10"
4x10 or (2) 2x12	9'-6" apart	<b>8'-0"</b>	2x6 or 2x8	16" apart or 24" apart	22"x22"x10" or 25" diameter x 10"
4x12	11'-0" apart	<b>8'-0"</b>	2x6 or 2x8	16" apart or 24" apart	22"x22"x10" or 25" diameter x 10"
4x6 or (2) 2x8	5'-6" apart	<b>10'-0"</b>	2x8 or 2x10	16" apart or 24" apart	18"x18"x 8" or 20" diameter x 8"
4x8 or (2) 2x10	7'-6" apart	<b>10'-0"</b>	2x8 or 2x10	16" apart or 24" apart	20"x20"x10" or 23" diameter x 10"
4x10 or (2) 2x12	9'-0" apart	<b>10'-0"</b>	2x8 or 2x10	16" apart or 24" apart	22"x22"x10" or 25" diameter x 10"
4x12	10'-6" apart	<b>10'-0"</b>	2x8 or 2x10	16" apart or 24" apart	24"x24"x10" or 27" diameter x 10"
4x6 or (2) 2x8	5'-0"	<b>12'-0"</b>	2x10 or 2x12	16" apart or 24" apart	18"x18"x8" or 20" diameter x 8"

1.) If you have a beam "A" that is:	And 2.) you have posts "B" supporting the beam spaced:	Then 3.) you can only span the joists "C":	And 4.) the minimum size joist you can use is:	And 5.) they can be spaced a maximum of:	And 6.) the footings "D" supporting the posts will need to be a minimum of:
4x8 or (2) 2x10	6'-6"	<b>12'-0"</b>	2x10 or 2x12	16" apart or 24" apart	20"x20"x10" or 23" diameter x 10"
4x10 or (2) 2x12	8'-6"	<b>12'-0"</b>	2x10 or 2x12	16" apart or 24" apart	22"x22"x10" or 25" diameter x 10"
4x12	10'-0"	<b>12'-0"</b>	2x10 or 2x12	16" apart or 24" apart	24"x24"x10" or 27" diameter x 10"
4x6 or (2) 2x8	4'-6"	<b>16'-0"</b>	2x12	16" apart	18"x18"x8" or 20" diameter x 8"
4x8 or (2) 2x10	6'-0"	<b>16'-0"</b>	2X12	16" apart	22"x22"x10" or 25" diameter x 10"
4x10 or (2) 2x12	7'-6"	<b>16'-0"</b>	2X12	16" apart	24"x24"x10" or 27" diameter x 10"
4x12	9'-0"	<b>16'-0"</b>	2x12	16" apart	26"x26"x10" or 30" diameter x 10"

6. After determining the sizes for the footings, posts, beams, and joist from the table, mark the information in the space provided below:

- Footing Size: \_\_\_\_\_ x \_\_\_\_\_ x \_\_\_\_\_, spaced \_\_\_\_\_ apart.
- Post Size: \_\_\_\_\_ x \_\_\_\_\_, spaced \_\_\_\_\_ apart.
- Beam Size: \_\_\_\_\_ x \_\_\_\_\_, spaced \_\_\_\_\_ apart.
- Joist Size: \_\_\_\_\_ x \_\_\_\_\_, spaced \_\_\_\_\_ apart.

7. Determine if you will be connecting to a band board (rim joist), see Figure 5; a concrete wall, see Figure 6; or a sill plate, see Figure 7. Note: This document cannot be used with masonry walls.

8. See Figures 15 to 34 for bracing, connection, built-up beam, footing, guardrail, and stairway details.

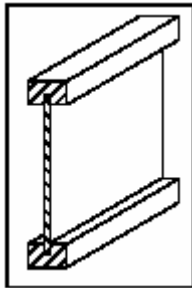
## POST SIZES

Post sizes are 4x4 minimum for decks six feet or less above the ground and 4x6 for decks over six feet above the ground. Decks with posts over ten feet above the ground cannot be used and require an engineered design. Use a minimum 4x6 post under all beam splices.

## LEDGER ATTACHMENT REQUIREMENTS

**General:** Ledger board attachments to the existing exterior wall shall be constructed in accordance with Figures 5 through 7. When attachments are made to the existing house band board, it shall be capable of supporting the new deck. If this cannot be verified or conditions at the existing house differ from the details herein, then a free-standing deck is required (See section on **Free-Standing Decks.**). You must verify the existing conditions in the field prior to applying for a building permit. Compliance with all the requirements herein is critical to ensure the structural stability of your deck.

**Siding and Flashing:** Siding or the exterior finish system must be removed prior to the installation of the ledger board. Flashing is required at any ledger board connection to a wall of wood-framed construction and shall be composed of copper (attached using copper nails), stainless steel, UV-resistant plastic or galvanized steel coated with 1.85 oz/sf of zinc (G-185 coating).



**Manufactured Wood Joist:** The term "MWJ" denotes manufactured wood "I" joists. See Figure 4. Examples of manufactured wood joists are TJI, GPI, and LPI. Many new homes constructed with MWJs include a 1¼-inch manufactured solid rim joist. See Figure 5. However, older homes constructed with MWJs may only include a plywood band board. In these cases, a freestanding deck or a full plan submission is required.

Figure 4: MWJ Profile

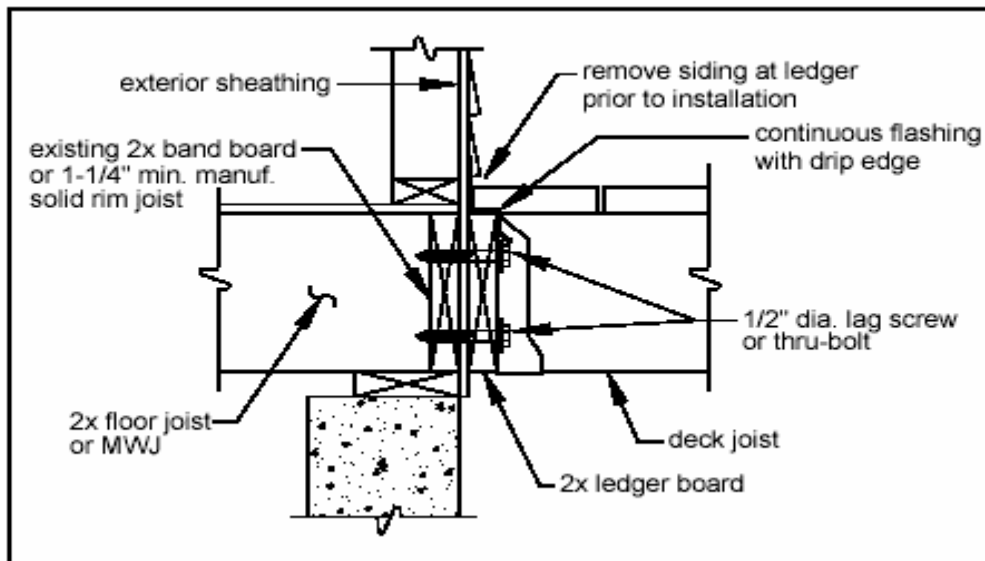


Figure 5 - Attachment of Ledger Board to Band Board

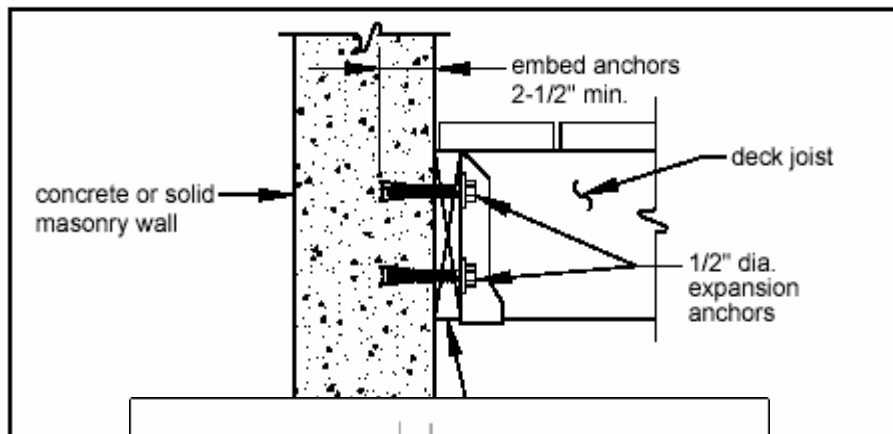


Figure 6 - Attachment of Ledger Board to Concrete or Solid Masonry Wall

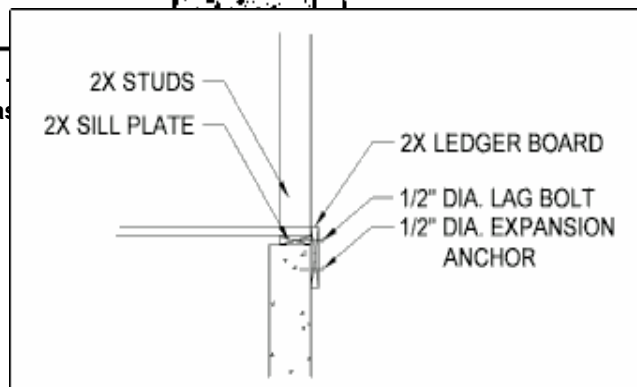
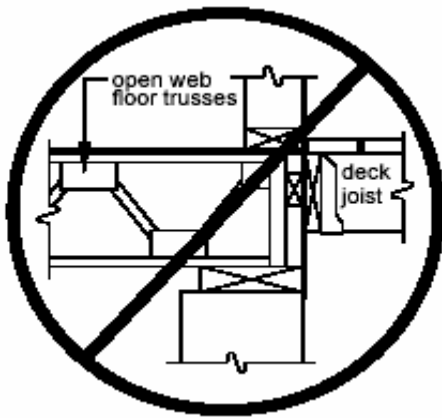


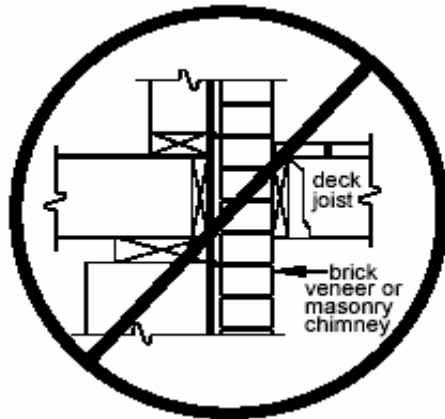
Figure 7 - Attachment of Ledger Board to Sill Plate

## PROHIBITED LEDGER ATTACHMENTS

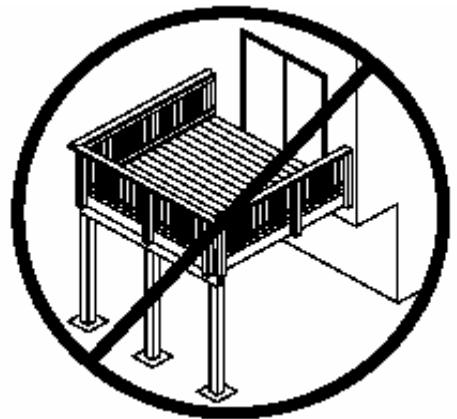
Attachments to the ends of premanufactured open web joists, to brick veneers, and to house overhang/bay windows are strictly prohibited; see Figure 8 through Figure 10. In such cases the decks shall be free-standing. See section on **Free-Standing Decks**.



**Figure 8: No Attachment To Open Web Trusses**



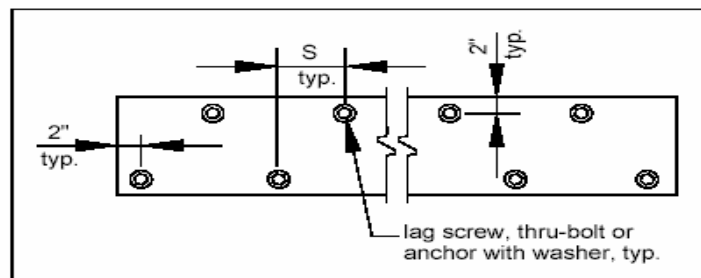
**Figure 9: No Attachment To Brick Veneer**



**Figure 10: No Attachment To House Overhang**

## LEDGER BOARD FASTENERS

All fastener types shall be spaced per Table B and installed per Figure 11. All fasteners shall be installed with washers and must be thoroughly tightened. **Adequacy of connections shall be verified by the building inspector.** If a ladder is required to access the ledger board, one must be provided by the property owner, permit holder, or their representative.



**Figure 11 - Ledger Board Fastener Spacing and Clearances**

**Table B  
Ledger Board Fastener Schedule**

Joist span	S (spacing), on center
0 – 8'	10"
8' – 10'	8"
10' – 14'	6"
14' – 16'	5"

**Thru-bolts:** Thru-bolts shall have a minimum diameter of  $\frac{1}{2}$ ". Lead (pilot) holes for thru-bolts shall be  $\frac{17}{32}$ " to  $\frac{9}{16}$ " in diameter. Thru-bolts must be equipped with washers at the bolt head as well as the nut. Thru-bolts are those where a hole is drilled all the way through the wood members and a nut and washer are attached to complete the connection.

**Expansion (Wedge) Anchors:** Use expansion anchors when attaching a ledger board to a concrete or solid masonry wall as shown in Figure 6. Bolt diameters of the anchors shall be a minimum of  $\frac{1}{2}$ "; in some cases, this may require an anchor size of  $\frac{5}{8}$ ". Minimum embedment length shall be  $2\frac{1}{2}$ ". Expansion anchors must have washers.

**Epoxy Anchors:** Epoxy anchors shall have a minimum diameter of  $\frac{1}{2}$ " and minimum embedment length of  $3\frac{1}{2}$ ". Installation shall be in strict conformance to the manufacturers' instructions. Epoxy anchors must have washers.

**IMPORTANT NOTE:** Expansion anchors and epoxy bolts must be installed as required by the manufacturer's instructions. This may include cleaning the holes drilled in the concrete/masonry to ensure they are free of dirt, debris, and moisture. Use of Epoxy Anchors requires an inspector to be present for the entire installation (Special Inspection). Improper installation of the anchors can result in catastrophic failure and collapse of the deck.

**Copies of the manufacturer's installation instructions must be submitted with this handout and permit application.**

**Lag Screws:** Lag screws shall have a minimum diameter of  $\frac{1}{2}$ " and shall be hot-dipped galvanized or stainless steel. Lag screws may be used only when the field conditions match those shown in Figure 12. **You must verify the existing conditions in the field prior to applying for a building permit and installing lag screws. Compliance with all the requirements herein is critical to ensure the structural stability of your deck.** See Figure 12 for lag screw length and shank requirements. All lag screws shall be installed with washers. Lag screws are those where a pilot hole is drilled into the wood members that are to be connected together and the lag is screwed into the hole, a washer is required on the lag head, but no nut and washer is needed on the screw end.

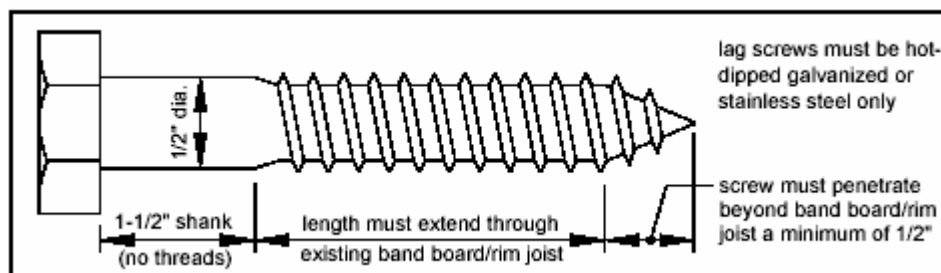


Figure 12 - Lag Screw Requirements

**Lag Screw Installation Requirements:** Each lag screw shall have lead (pilot) holes drilled as follows: 1) drill a  $\frac{1}{2}$ " diameter hole in the ledger board, 2) drill a  $\frac{5}{16}$ " diameter hole into the solid connection material of the existing house. **DO NOT DRILL A  $\frac{1}{2}$ " DIAMETER HOLE INTO THE SOLID CONNECTION MATERIAL.**

The threaded portion of the lag screw shall be inserted into the lead hole by turning. DO NOT DRIVE WITH A HAMMER. Use soap or a wood-compatible lubricant as required to help facilitate tightening. Each lag screw shall be thoroughly tightened.

## FREESTANDING DECKS

Decks that are free-standing do not utilize the exterior wall of the existing house to support vertical or lateral loads. Support at or near the house is provided by an additional beam and posts. See Figure 12. Beam size is determined by Table A.

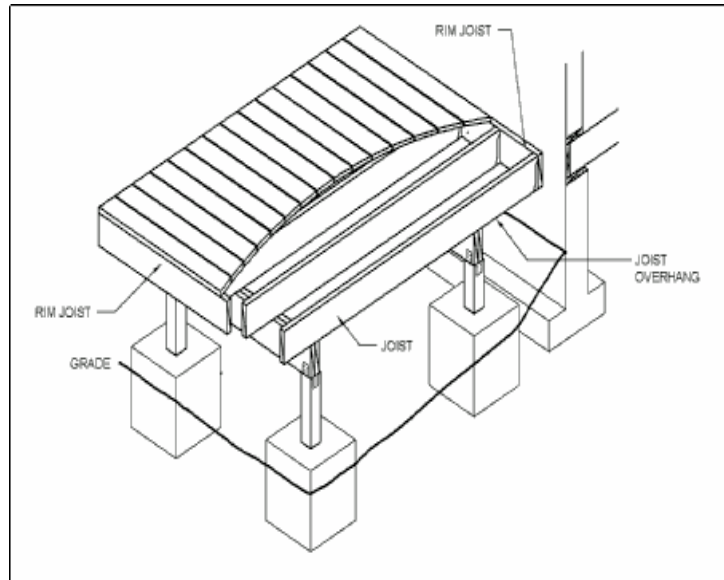


Figure 13 - Free-Standing Deck

## LATERAL SUPPORT OF DECKS

Decks greater than four feet above grade shall resist lateral loading and movement by the following methods:

### Diagonal Cross

**Bracing:** Provide diagonal cross bracing as shown in Figure 14. Bracing shall be located between posts parallel to beams and bolted by a minimum of two 1/2" diameter by 6" lag bolts or two 1/2" thru-bolts at each end to the posts as shown. Diagonal bracing shall also be located perpendicular to beams, and in such cases, bracing shall be bolted to the post and joist above the post location. If the deck is free-standing, diagonal bracing must be provided on all the posts and in both directions.

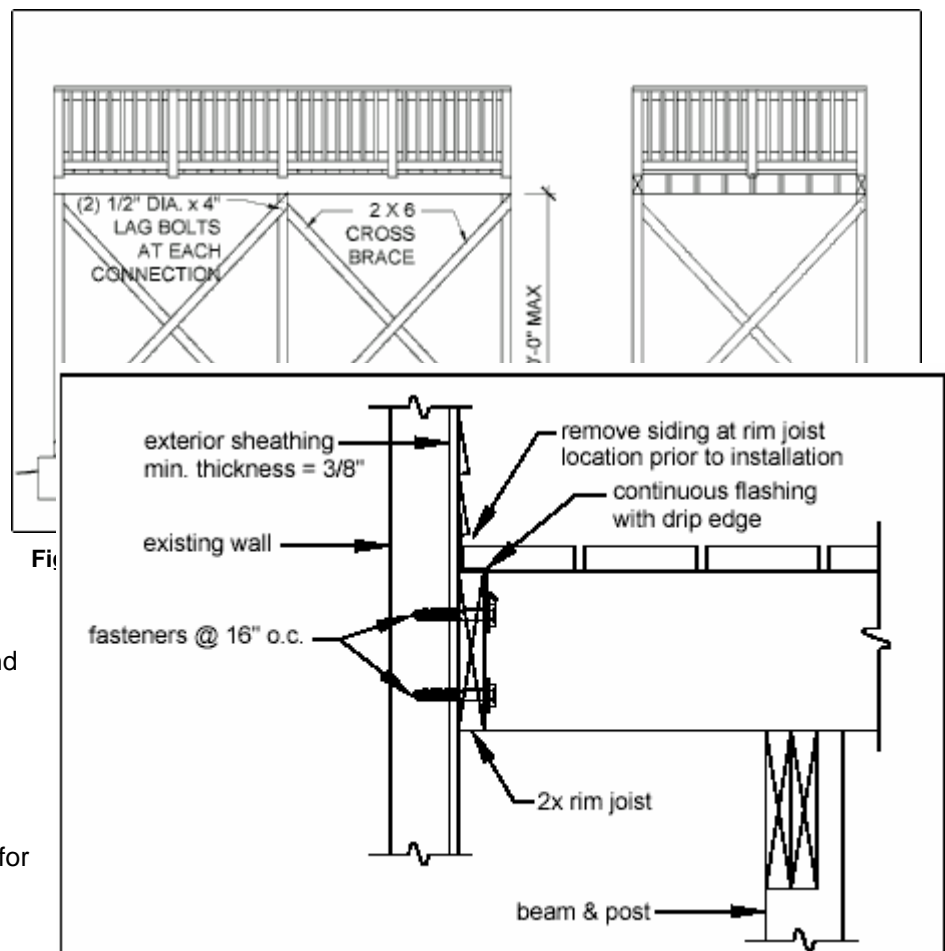


Figure 15 - Attachment to House Lateral Support

### Attachment to House:

Lateral support is provided for

one-half of the deck by the attachment of the deck rim joist to the existing house as shown in Figure 15 (the beams and posts furthest from the house still require the diagonal bracing as shown in Figure 14). The existing exterior wall must have sheathing consisting of structural wood panels with a minimum thickness of  $\frac{3}{8}$ " , and the fasteners shall attach to an existing band board or wall stud. The deck rim joist may also attach to a concrete wall, but not to a brick veneer. **You must verify this condition in the field prior to utilizing this method.** Fasteners shall be 16" on center and must penetrate existing wall studs. See also the provisions noted on page 8. Flashing over the rim joist is required and must be installed in accordance with the flashing provisions noted on page 7.

## JOIST HANGERS

Joist hangers, as shown in Figure 16, shall have a minimum capacity of 1,000 pounds. Joist hangers used shall be manufactured for their intended lumber size. Joist hangers shall be galvanized with 1.85 oz/sf of zinc (G-185 coating) or shall be stainless steel.

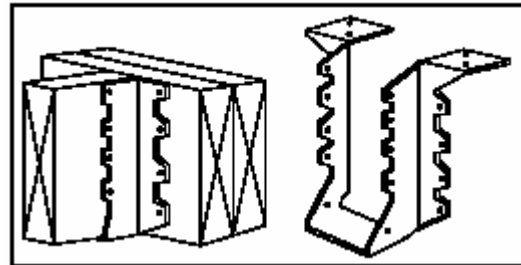


Figure 16 - Typical Joist Hangers

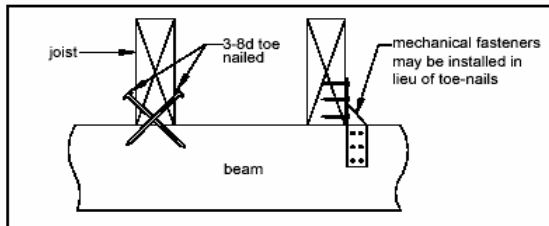
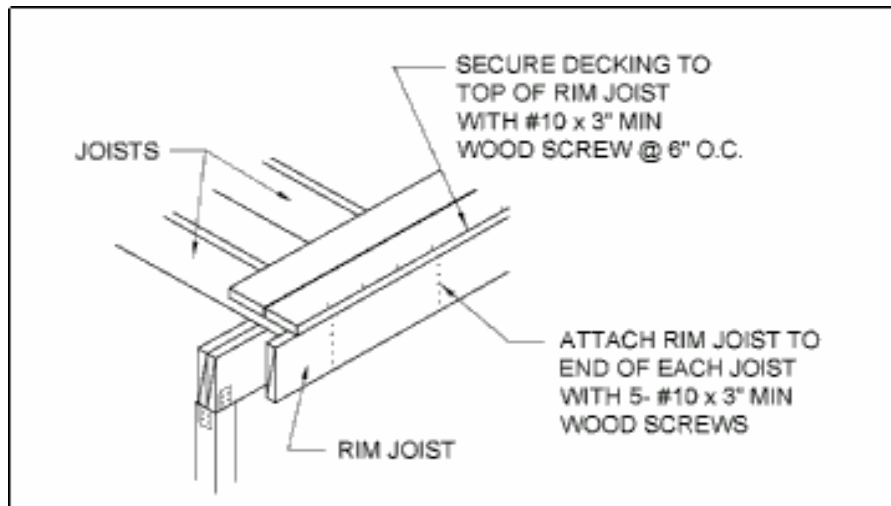


Figure 17 - Joist-to-Beam Detail

**Joist-to-Beam Connection:** Each joist shall be attached to the beam as shown in Figure 17. Mechanical fasteners shall be galvanized with 1.85 oz/sf of zinc (G-185 coating) or shall be stainless steel.

### Rim Joist Requirements:

Attach a continuous rim joist to the ends of joists as shown in Figure 18. Please note that the rim joists are required at both ends of joists associated with free-standing decks. Minimum rim joist dimensions shall be equal to the dimensions of the joist.



### Built-Up Beam Requirements:

Built-up beams

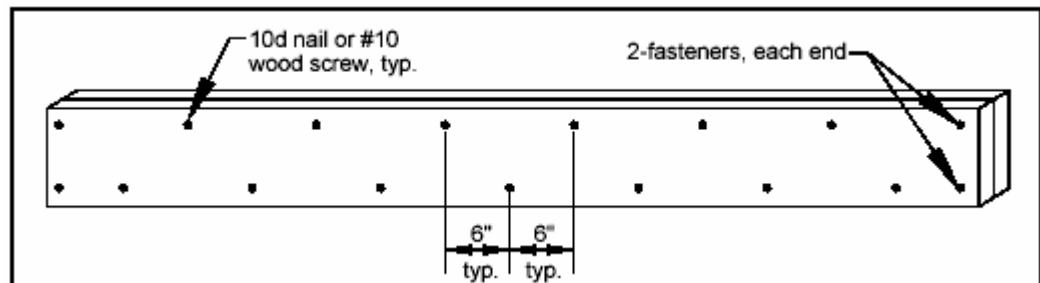


Figure 19 - Built-Up Beam Detail

shall be assembled in accordance with Figure 19. The nailing pattern shall be staggered as shown.

## POST-TO-BEAM REQUIREMENTS

The post-to-beam connection shall be made with premanufactured mechanical connectors. Mechanical connectors shall be galvanized with 1.85 oz/sf of zinc (G-185 coating) or shall be stainless steel as shown in Figure 20. Post-to-beam connections may also be accomplished using a minimum 6x6 post notched for a 4x beam as shown in Figure 21. All thru-bolts shall have washers at the bolt head and nut.

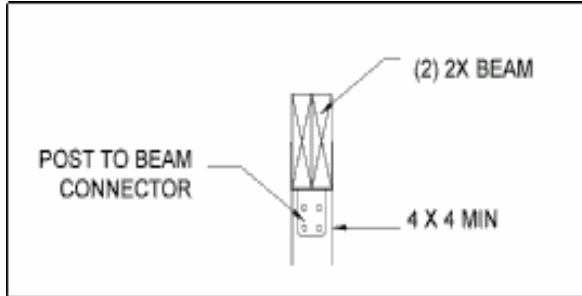


Figure 20 - Post-to-Beam Requirements

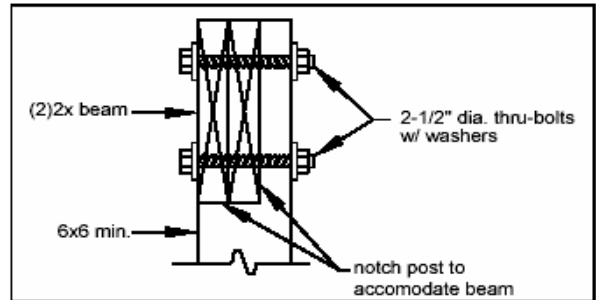


Figure 21 - Post-to-Beam Requirements

## FOOTINGS

See Table A for footing size and footing thickness and Figure 22 for post attachment requirements. All footings shall bear on solid ground. Bearing conditions shall be verified in the field by your local jurisdiction during the footing inspection, prior to placement of concrete. Footings closer than 3'-0" to the existing exterior house wall must bear at the same elevation as the existing wall footing. **Do not construct footings over utility lines or enclosed meters. Call 1-800-332-2344 before you dig.**

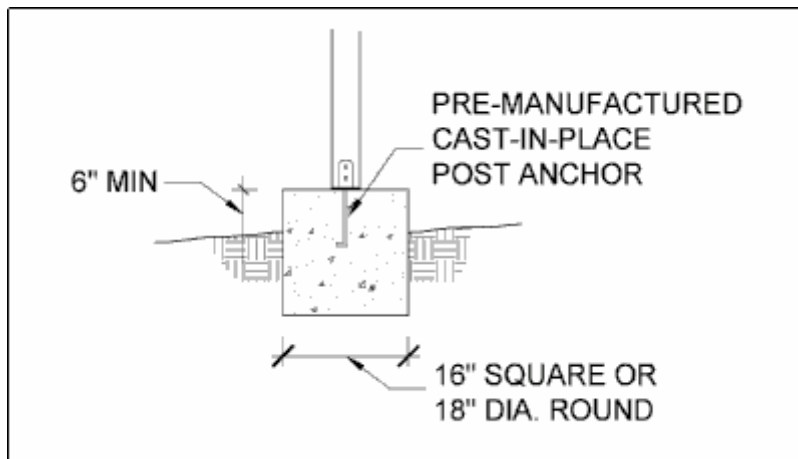


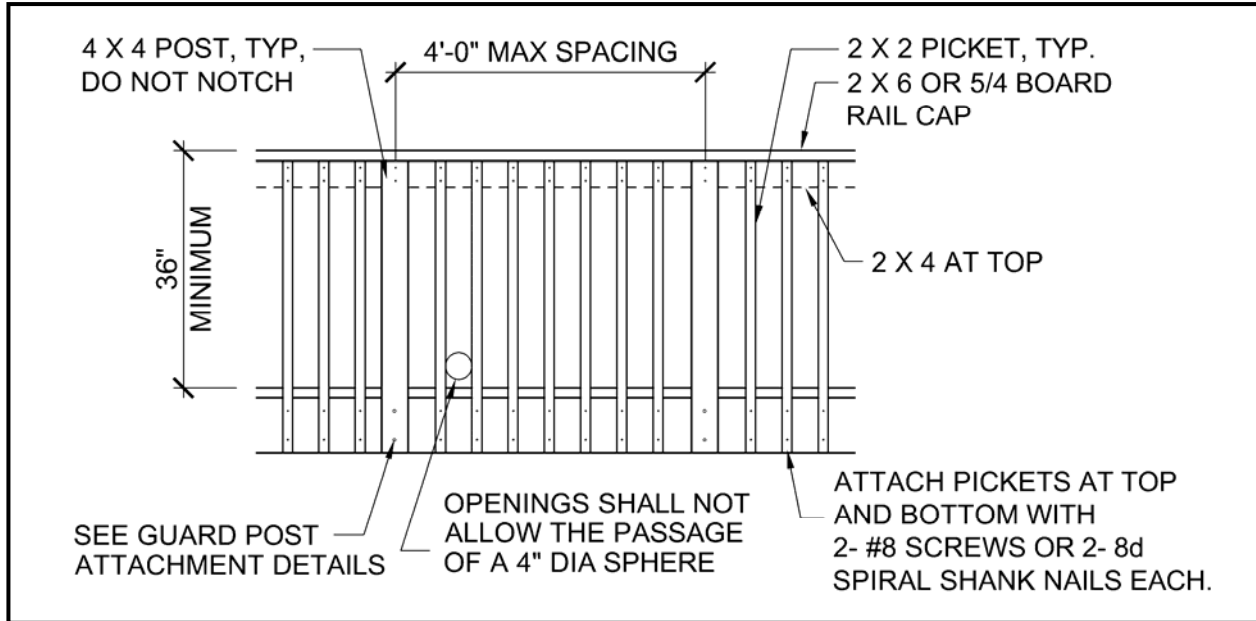
Figure 22 - Typical Footing Detail

Premanufactured post anchors shall be galvanized with 1.85 oz/sf of zinc (G-185 coating) or shall be stainless steel. Post anchors shall be capable of supporting a minimum of 3,000 pounds. Footings for freestanding decks (those not attached to the house) are not required to be placed below the frost line. Footings for freestanding decks may reduce the footing thickness to a minimum of eight inches.

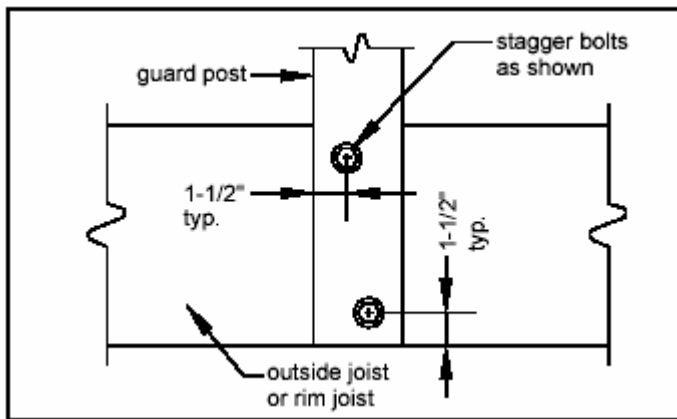
**Note: Footings for decks constructed according to this handout shall not be placed on ground with a slope greater than 2 horizontal for every 1 vertical. Footings adjacent to the top of a retaining wall must be set-back from the top of the wall a distance equal to the height of the wall, or be placed below grade an amount equal to the height of the retaining wall.**

## GUARDRAIL REQUIREMENTS

Decks less than 30" above grade are not required to have a guardrail; however, if one is installed, it is a good idea to follow these requirements. All decks and stairways over 30" above grade require guardrails. All guardrails shall be constructed in strict conformance with the figures herein; any deviations require a plan submission.

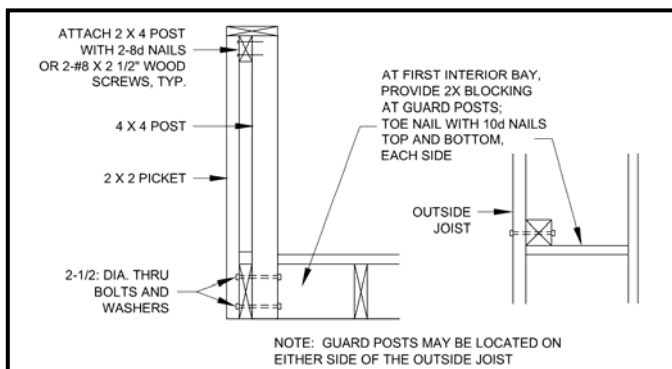


**Figure 23 – Typical Guardrail Detail**



**Figure 24 - Guardrail Post Attachment Detail**

Any prefabricated wood, plastic, or manufactured guardrail system purchased from a home center store, lumber company, or similar will also require a plan submission. The guardrail shall be designed to withstand a concentrated load of 200 pounds anywhere along its length, and the infill area is designed to withstand a load of 50 pounds on a square foot area.



**Figure 25 - Guardrail Post to Outside Joist Detail**

**Guardrail Post Attachment:**  
Guardrail posts shall be spaced per Figure 23 and attached per Figures 24 through 27.

As shown in Figure 27, guardrail posts may be attached to the outside face of the rim joist. However, in this condition, and in addition to the attachment requirements shown in Figure 27, the rim joist must be fastened to the next adjacent joists with 20 gage *stud tie plates* attached per the manufacturer's instructions, with hot-dipped galvanized or stainless steel fasteners. Stud tie plates must be galvanized

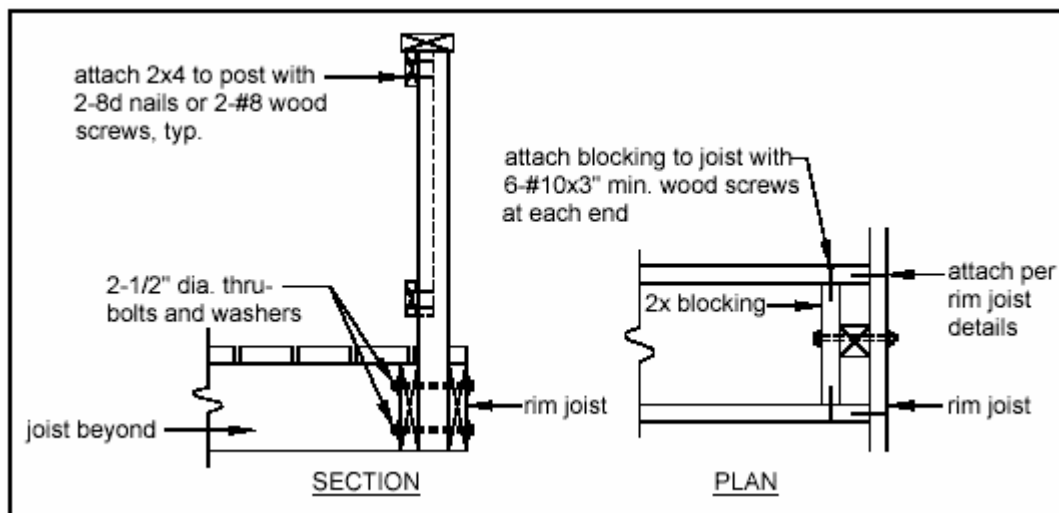


Figure 26 - Guardrail Post to Rim Joist Detail, Option I

coating from USP. **If you are unable to use *stud tie plates* in this condition, you must follow the requirements of Figure 26.**

with 1.85 oz/sf of zinc (G-185 coating) or shall be stainless steel. Look for model number SP1 in a Zmax coating from Simpson Strong-Tie or model number SPT22 in a triple zinc

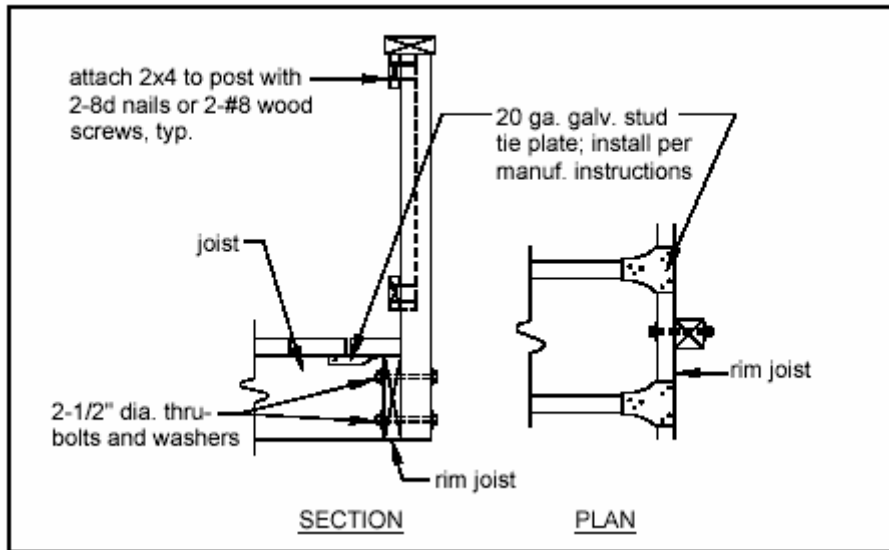


Figure 27 - Guardrail Post to Rim Joist Detail, Option 2

### STAIR REQUIREMENTS

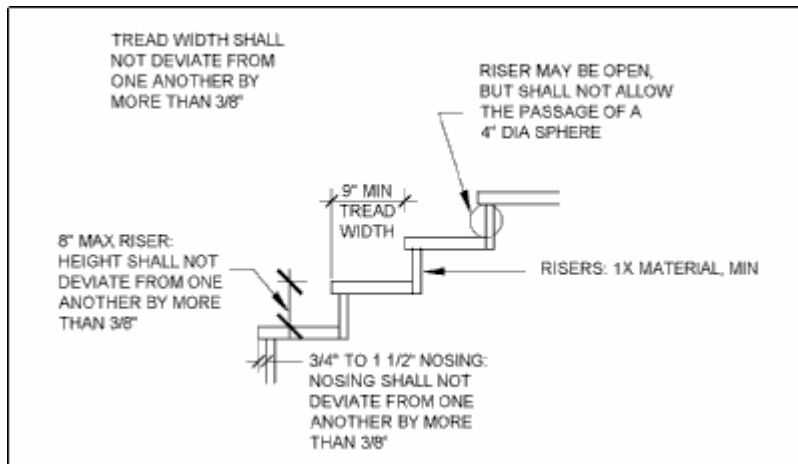


Figure 28 - Tread and Riser Detail

Stairs, stair stringers, and stair guardrail shall meet the requirements shown in Figure 28 through Figure 34. All stringers shall be minimum 2x12. A level landing minimum 3 feet by 3 feet is required at the top (usually this is the deck) and at the bottom (usually a concrete pad) of the stairway. A flight of stairs shall not have a vertical rise greater than 12 feet between floor levels or landings.

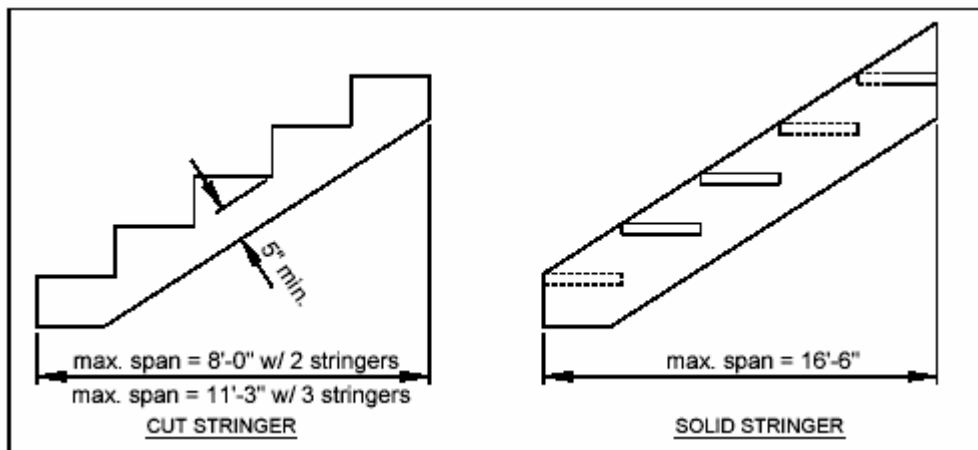


Figure 29 - Stair Stringer Requirements

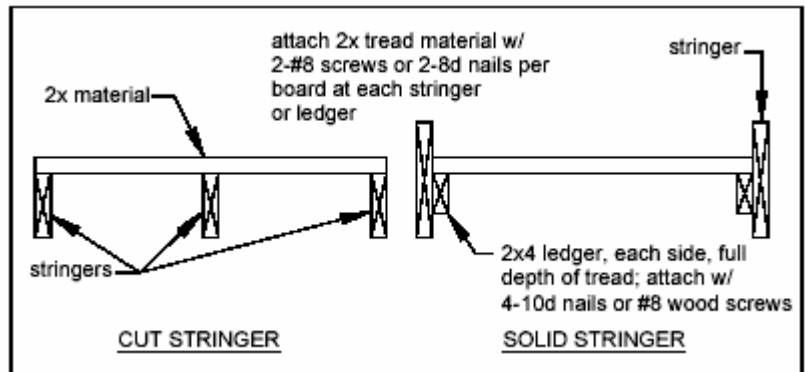


Figure 30 – Tread Connection Requirements

Note: The stair design in this document is for a three-foot wide maximum stairway with minimum 2x tread material. Plastic or composite decking products may be used for stair treads; however, they may require additional stair stringers for bracing. Check with the manufacturers requirements,

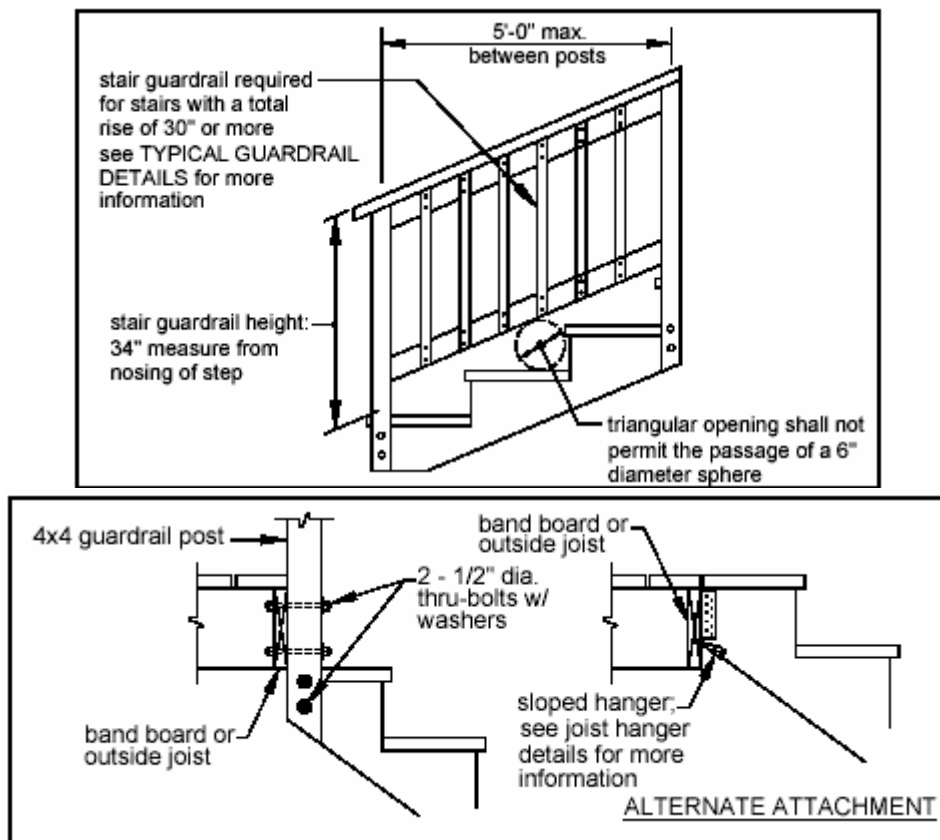


Figure 32 – Stair Stringer Connection Detail

## STAIR HANDRAIL REQUIREMENTS

All stairs with four or more risers shall have a handrail on one side. Handrails shall be graspable and shall be of decay-resistant and/or corrosion-resistant material. See Figure 33.

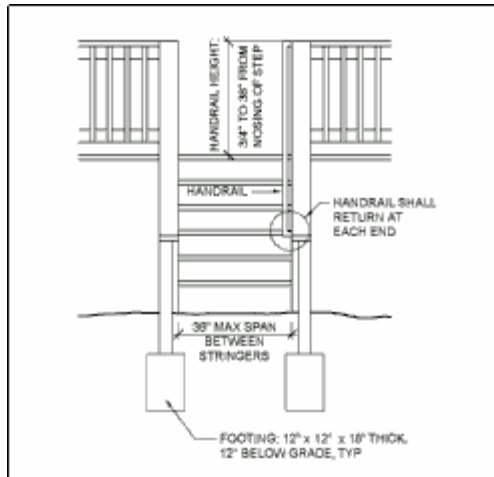


Figure 34 – Miscellaneous Stair Requirements

The hand grip portion, if circular, shall be between 1¼" and 2" in cross section. Shapes other than circular shall have a perimeter dimension between 4" and not greater than 6¼" with a maximum cross sectional dimension of 2¼". All shapes shall have a smooth surface with no sharp corners. Handrails shall run continuously from a point directly over the lowest riser to a point directly over the highest riser and shall return to the guard at each end. See Figure 34. Handrails may be interrupted at guardrail posts only at a turn in the stair.

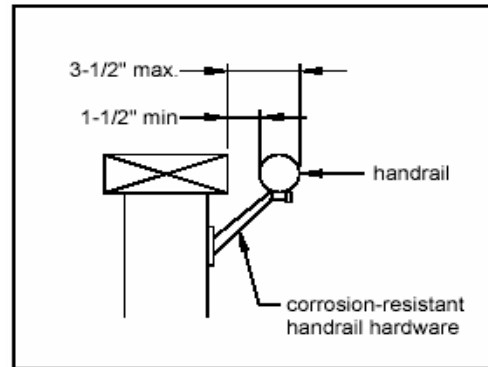


Figure 33 – Handrail Requirements

## FRAMING AT CHIMNEY OR BAY WINDOW

All members at a chimney or bay window shall be framed in accordance with Figure 35. Headers with a span length greater than 6'-0" require a plan submission.

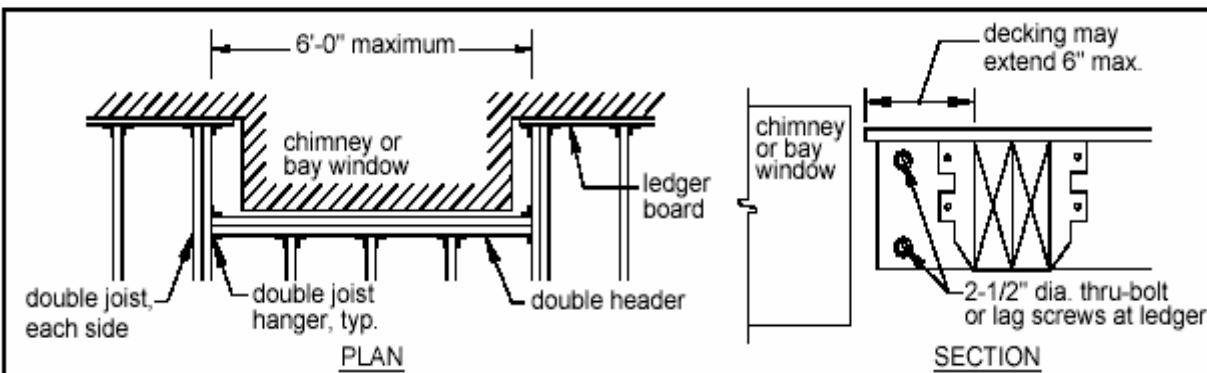


Figure 35 - Requirements for Framing at Chimney or Bay Window